

A1 Spring Sign Assembly Instructions

Note: to avoid any accidental loss of components, please do not dispose of packaging until the sign is fully assembled.

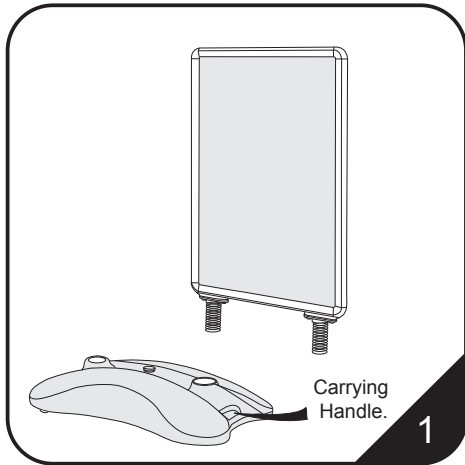

The cartons will contain a water-fill base and a poster frame.

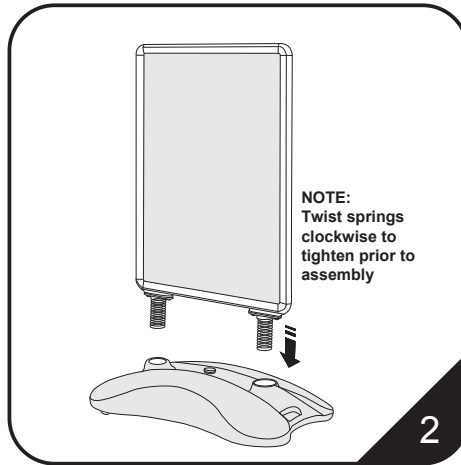

Insert the legs of the poster frame into the holes of the water-fill base to check fit.
NOTE: To adjust spring position loosen them by turning anti-clockwise. Re-tighten before assembly.

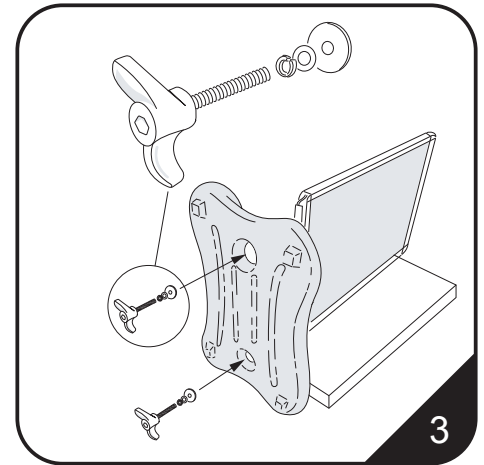

Resting the poster frame on the packaging, use the fixings shown to attach the water-fill base to the poster frame. Ensure fixings are fully tightened for correct sign performance.

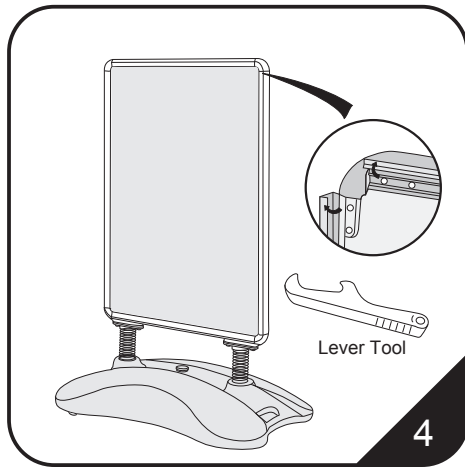

Use the lever tool to open the poster frame sides.

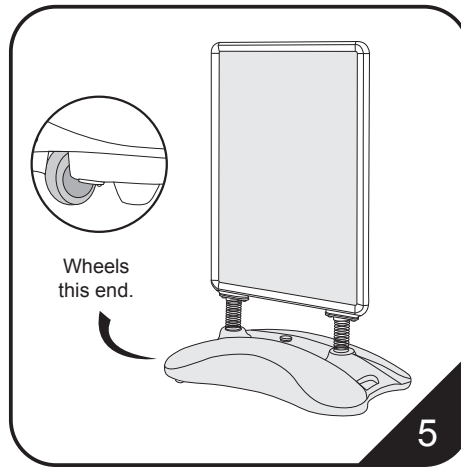

Place the poster in & then the clear plastic poster cover before closing the poster frame sides. Repeat for the second side. The sign is now ready to be moved.



Please fill full with water, or use sand in the base.

Note: - the handle in the base is for carrying, pre-assembly and filling. To move the sign when assembled and with the base filled we recommend tilting the sign and moving as shown here.

Take care not to move the sign over high steps or kerbs. Always position the sign on an even flat surface.

